

CRUSADER

friction hinges

The Crusader range of friction hinges offer major advances in fitting, weathersealing and operational performance.

Manufactured from high quality stainless steel, the hinge is designed for high performance on all window types and sizes.

The pointed sash arm and nylon end cap together provide an excellent gasket compression and smooth engagement.

Restrictor versions (see SXL).

The security performance of the hinge may be enhanced by the fitting of Hingeguard protection plates.

Designed to engage only when the window is under attack, Hingeguard prevents disengagement by supporting the hinge end cap.

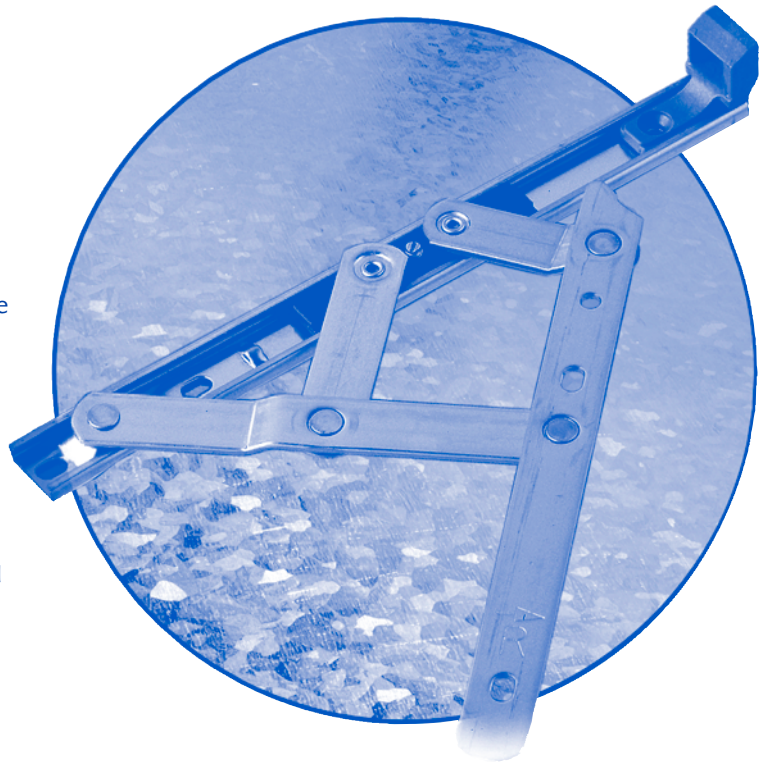

Technical information

Corrosion resistance:	Meets the Requirements of BS EN 1670:2007 Grade 4 (240 hrs)
Performance:	Meets the requirements of BS6375-1:2004 Tested to 20,000 cycles of opening
Operation:	Meets the requirements of BS6375-2:1987

Material specification

Bars, Arms & Rivets:	Stainless Steel BS EN 10088-2:2005 Ferritic – 1.4016 (430 S17)
End Cap:	Grey Nylon
Mouldings:	Glass filled Nylon
Friction Screw:	Brass BS EN 12164:1998 CW614N

Product options

Available in sizes 8", 10", 12", 16", 20" and 24".
Top hung or side hung 13.5mm, 15.5mm or 16.5mm stack.
Restricted 14.5mm stack or 16.5mm stack (see SXL).
See opposite for complete list of product codes.

Dimensions

Size mm	Nom inch	Dim. A	Dim. B	Dim. C1	Dim. C2
210	8	177.5	136	93.5	-
262	10	229	180.5	126	-
311	12	278.5	201	168.5	-
414	16	380.5	232.5	201	-
516	20	483.5	186.5	266.2	93.5
616	24	583.5	237.5	316	180

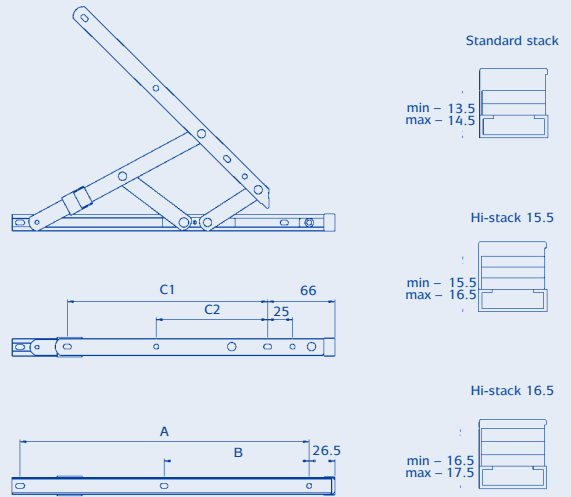

Weights and sash sizes

Size mm	Nom inch	Approx Opening Angle	Max Width mm	Max Height mm	Max sash Weight (kg)
210	8 Top	53	1000	300	10
262	10 Top	80	1100	400	14
311	12 Top	80	1200	550	16
414	16 Top	75	1200	650	18
516	20 Top	40	1200	850	22
616	24 Top	45	1200	850	24
311	12 Side	80	600	1200	18
414	16 Side	75	650	1300	18



CRUSADER

Part numbers

Size		13.5mm	15.5mm	16.5mm
Top Hung				
8"	210mm	WFCNTL0860	WFCNTE0860	WFCNTG0860
10"	262mm	WFCNTL1090	WFCNTE1090	WFCNTG1090
12"	311mm	WFCNTL1290	WFCNTE1290	WFCNTG1290
16"	414mm	WFCNTL1690	WFCNTE1690	WFCNTG1690
20"	516mm	WFCNTL2040	WFCNTE2040	WFCNTG2040
24"	616mm	WFCNTL2440	WFCNTE2440	WFCNTG2440
Side hung				
12"	311mm	WFCNSL1290	WFCNSE1290	WFCNSG1290
16"	414mm	WFCNSL1690	WFCNSE1690	WFCNSG1690

RESTRICTOR – See SXL data sheet

Packing information

Size		No per pack	Weight
8"	210mm	50	14kg
10"	262mm	50	17kg
12"	311mm	50	22kg
16"	414mm	25	15kg
20"	516mm	25	18kg
24"	616mm	25	21kg