

FITTING INSTRUCTION

FAB & FIX SAFE-T-BAR

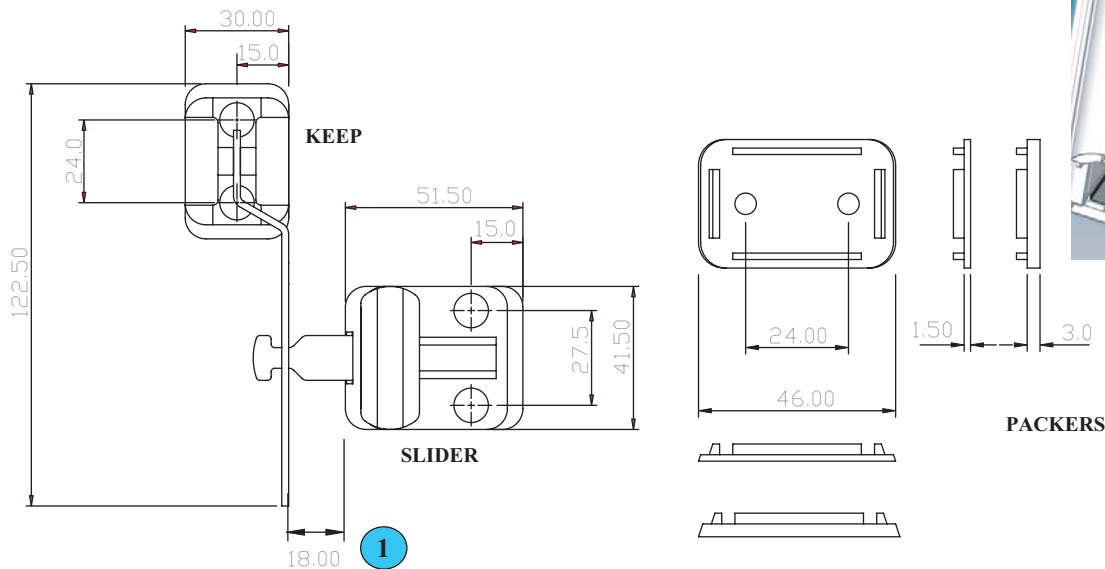

1). Locate the Safe-T-Bar onto section leaving approximately 18mm between Keep Base and Sliding Bar Base as shown above. The Safe-T-Bar should be placed where the operator can easily reach it.

Open-In Doors.

Sliding Bar Base.

- 2). Sliding Bar Base is to be fixed to the moving part of the door (Sash). Once correct location has been found, drill 3mm pilot holes using the Sliding Bar Base as a Jig.
- 3). If after drilling through 2 layers of walls or webs of PVC-u the 3mm drill encounters section re-inforcing, steel or aluminium, fixing the Safe-T-Bar to this re-inforcement will create a solid fix. Either drill through the re-inforcing section or use a self tapping screw to penetrate. If no re-inforcement is found, use PVCU Screws.
- 4). To obtain a solid fix use re-inforcing retaining screws. Once fitted, operate the sliding bar to ensure correct function.

Keep Base.

- 5). Depending on profile, fit packers if necessary to align the Sliding Bar centrally with the bar on the Keep Base.
- 6). Once correct alignment is found, drill 3mm pilot holes using the Keep Base as a Jig. Repeat steps 3 and 4 to ensure a solid fix.
- 7). Making sure the door is properly closed, operate the Safe-T-Bar to ensure all fixtures are correctly aligned.

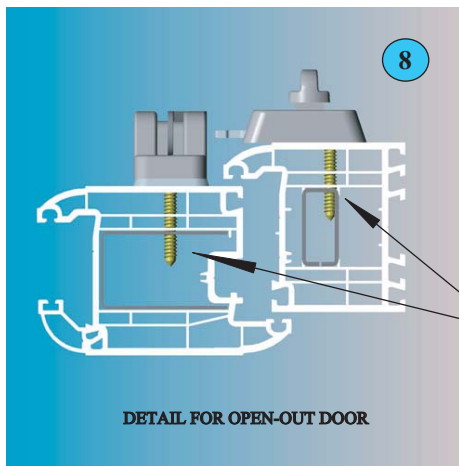
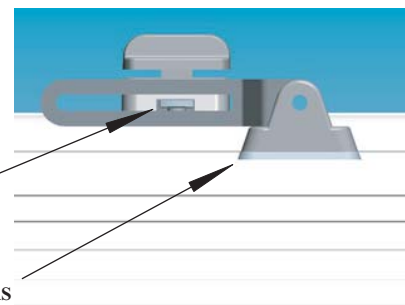
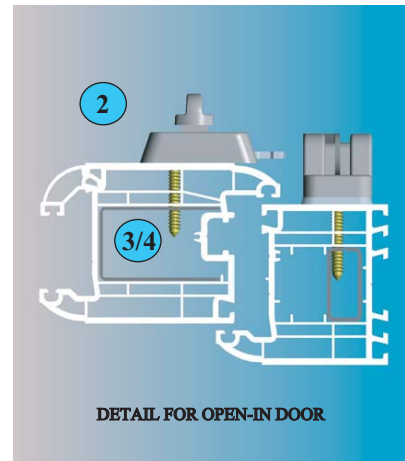

Open-Out Doors.

8). With doors that open outwards, the Sliding Bar Base is to be fixed to the Door Frame and the Keep Base fixed to the Door Sash.

NOTE: For all other fixture details repeat steps for Open-In Doors.

PVCU SCREWS OR
SELF-TAP SCREWS
DEPENDING ON SITUATION.

Issue	Description	Drawn	Chkd	Date
1	ORIGINAL ISSUE	WMH	AW	28.05.05



The Moorings Business Park
Channel Way
Exhall, Coventry
CV7 9FW
T: 02476 585 785
F: 02476 585 786
e: sales@fabnfix.co.uk
www.fabnfix.co.uk