

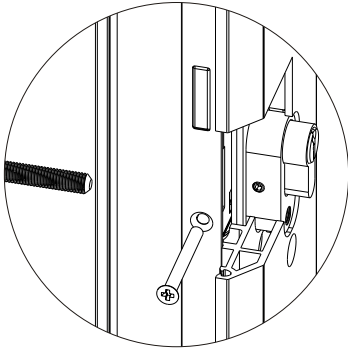

grouphomesafe

## CYLINDER GUARD



DCLSCO0004A

For Composite Doors - Routing Prep must be from the front face of the door. Requires prep change only. No fitting jig required.

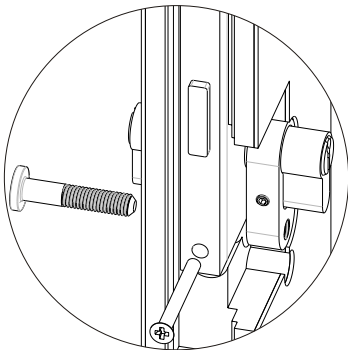

DCLSCO0005A

For UPVC Doors (Inward and Outward opening) - Unsuitable for: Fullex, Millenco, Paddock & Yale. Requires prep change only. No fitting jig required.

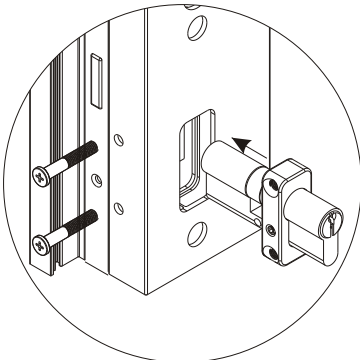

DCLSCO0007A

For UPVC (Inward opening only) & Composite Doors NON lock specific. - Unsuitable for UPVC Outward opening Resi & French doors.

Ideal for remedials (except outward opening) but requires a fitting jig (see below).

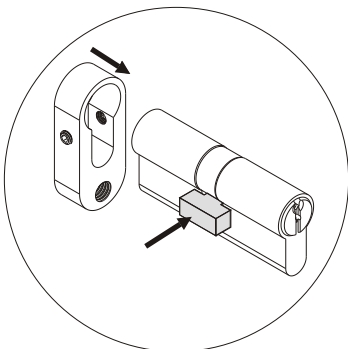

DCLSXO0001

A setting block is recommended for ensuring that the guard is correctly located onto the cylinder so that it does not foul on the lock gearbox casing.

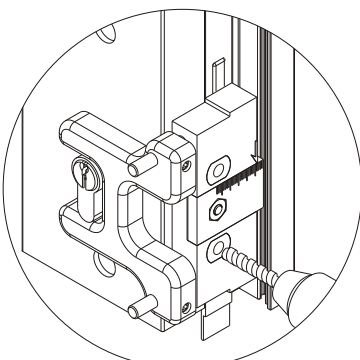

DCLSJO0001

The drill jig is used for DCLSCO0007 and enables the holes for the 2 fixing screws to be accurately drilled.



grouphomesafe

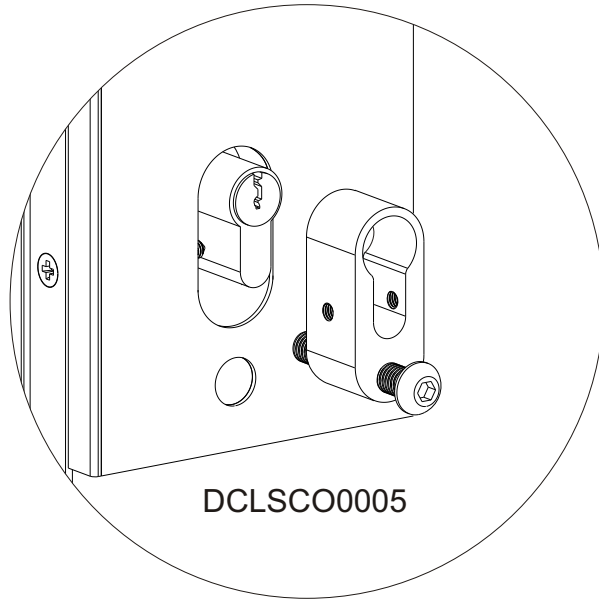

**INWARD OPENING**

**OUTWARD OPENING**

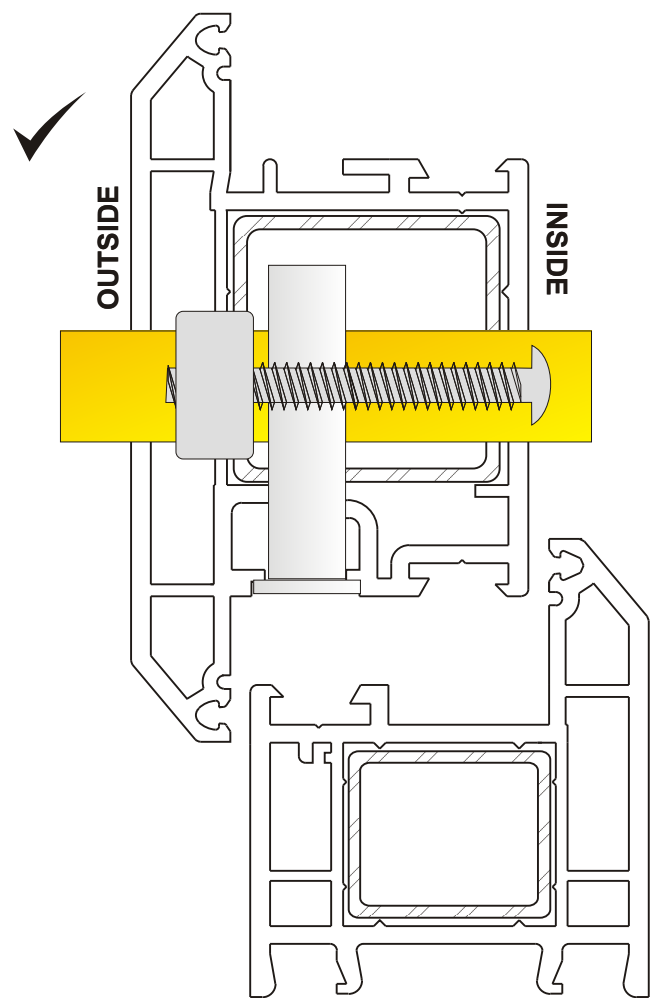
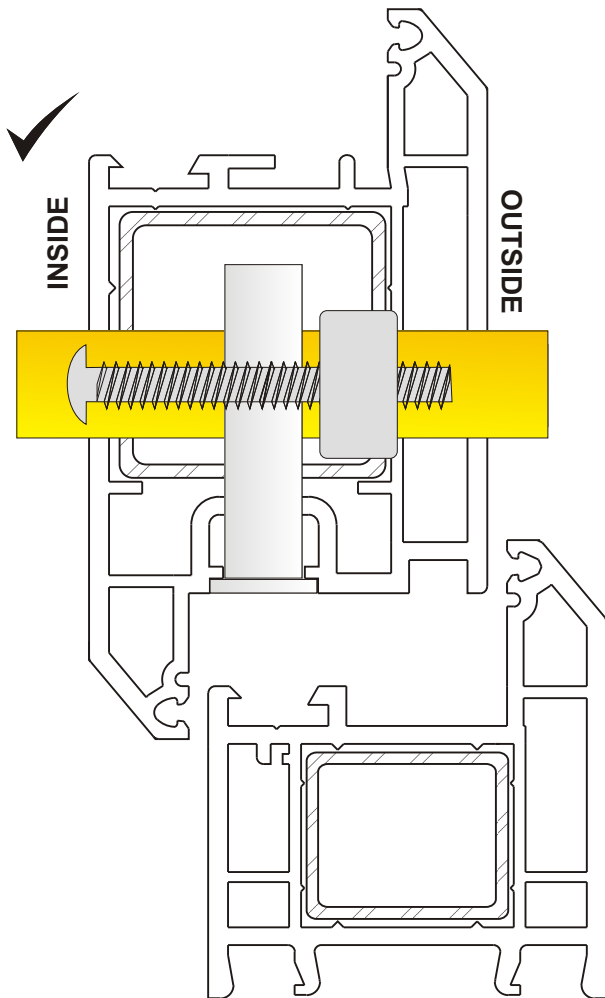



grouphomesafe▲

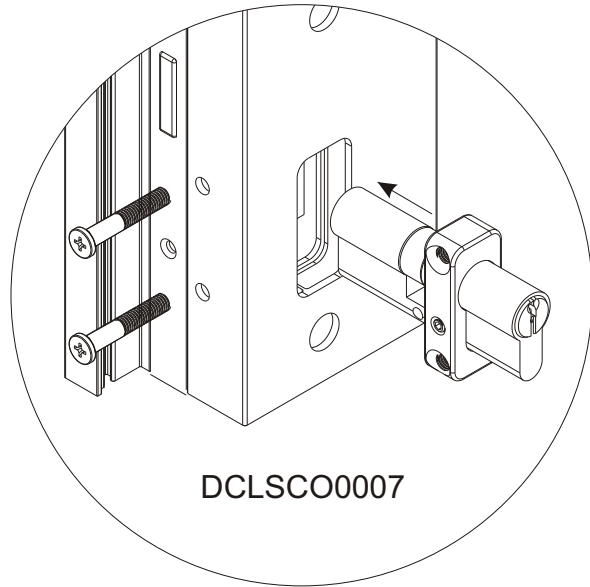

**INWARD OPENING**

**OUTWARD OPENING**

