

Sashlocks - Reversing the sashbolt (latch)

1 Follow instructions in this box for all Mortice Sashlocks which use screw(s) in latchbolt for reversing latch only

Remove the latch bolt screws, slide out the bolt, revolve through 180° and replace back into lock. Refit the screw tightly.

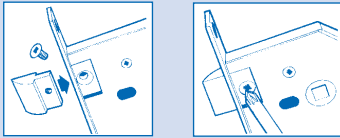

2 Follow instructions in this box for 2/3 Lever Locks and Bathroom Locks only

Instructions for rehanding the sashlock-
Reversing the sashbolt (latch)

Either: Pull the latch bolt clear of the forend with a pair of pliers and rotate the bolt head 180°

Or: Lever the bolt head clear of the forend using a screw driver. Insert behind the bolt head as shown and rotate the bolt head 180°.

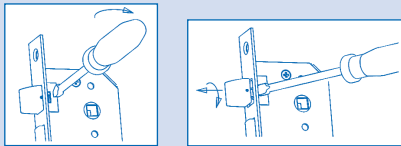

Fitting Rebate Sets: BS Fortress, Viscount, Euroshield & 3Lever

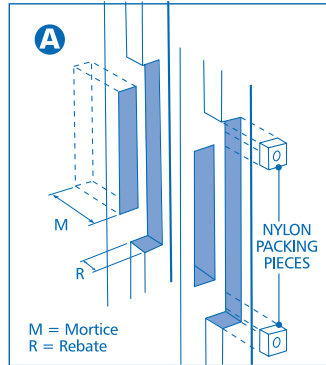

Lefthand door

NOTE: Please read the instructions overleaf for a general guide to fitting

- A** Select position of lock of door and chisel the mortice and rebate. Place face plate over the lock. Insert the lock into the door using the nylon packing pieces to bring it flush with the door edge.

Ensure packing pieces are in line with the holes in the face plate and secure the lock with screws provided

Please note no nylon packing pieces required with the 2 lever Rebated Sashlock or 2/3 lever Rebate kits

- B** On the opposite door select the position for the box striker rebate and secure with the screws provided.

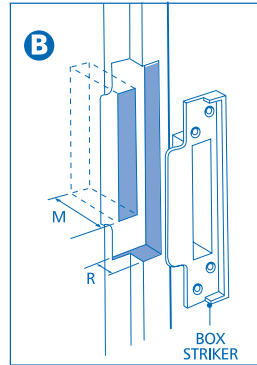

Righthand door

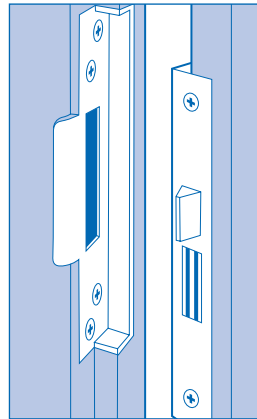

Guarantee -

The guarantee covers defective workmanship should the lock become inoperable with the periods listed below

- 25 Years for Fortress BS Classic
- 10 Years for Fortress BS, 5 Lever and Cylinder type locks
- 5 Years for 2 & 3 Lever, Bathroom Locks and Mortice case only locks

Any repaired or replaced goods shall be delivered by the Company free of charge to the original point of delivery. Proof of purchase (receipt) must be produced.

The Guarantee does not cover:

1. The company will not be liable for any incidental damage and/or rectification work which is undertaken as a result of any defective product without prior approval from the company.
2. Incorrect fitting
3. Misuse, none authorised repairs, or incorrect maintenance.
4. Tarnishing or decolouration of product as this is affected by environmental conditions.

* To ensure smooth latchbolt operation, it may be necessary to lubricate both the latchbolt and the box striker every 6 months by applying a light oil and then wiping with a soft cloth

350-544

For consumer advice.

TECHNICAL HELPLINE
(01922) 490050

Call 01922 490000 for
your **FREE** brochure.
www.era-security.com

Information correct at time of print 21/05/2008



This booklet includes fitting instructions for ERA Deadlocks & Sashlocks

Including BS Fortress, Viscount, Euro Viscount,
2 Lever & 3 Lever Mortice Locks
(Suitable for Doors over 36mm)

Please Note: Although the instructions and illustrations shown in this leaflet refer to sashlocks, the same fitting procedure applies to deadlocks.

To fit the ERA range of mortice locks, you will require the following tools -

- drill & drill bits (see below)
- posidrive screw driver
- mallet
- pencil
- chisel

Drill bit sizes:-

 British Standard Fortress/Classic	17mm	1 1/16"
5 lever, Euro and Oval		
Viscount & non Euro Viscount	17mm	1 1/16"
2/3 Lever & Bathroom Mortice Locks	16mm	5/8"

It is recommended that suitable pilot holes be drilled before fitting fixing screws, especially in hardwood.

Preparing the door

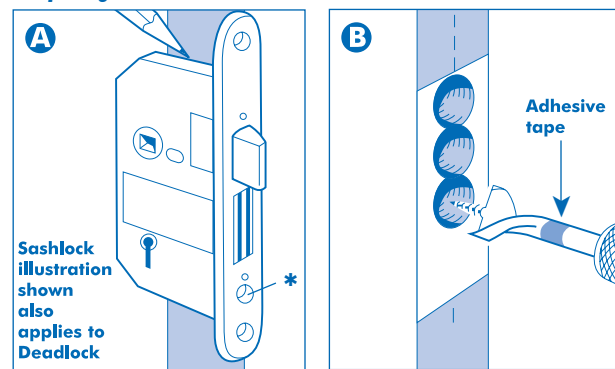

Mark position of lock

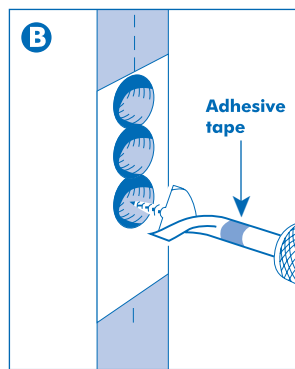

Drill holes for mortice

* NOTE: The hole in the lock end face (marked*) is only used with Cylinder Mortice Door Locks

- A** Position lock body as near to the mid-height of the door as possible.

Place lock body against door edge and mark top and bottom of lock body on door edge, avoiding joints of cross members in the door.

- B** Between these two lines mark the central vertical position (dotted line). Along this vertical line drill a series of overlapping holes to the lock depth.

In order to drill to the correct depth apply adhesive tape to the drill bit to the measured lock depth (including the forend and face plate).

- C** Carefully chisel out remaining wood to make a rectangular hole (mortice) to accommodate lock body.

Fitting the lock

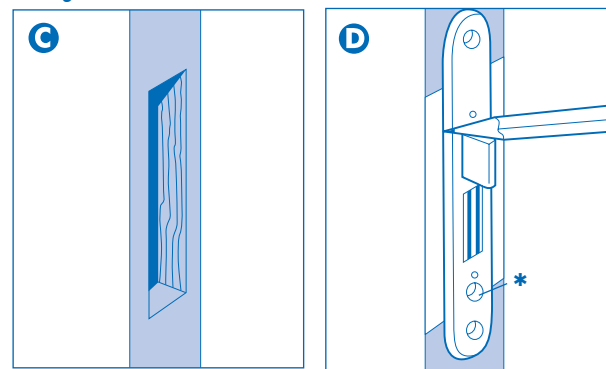

Chisel out mortice

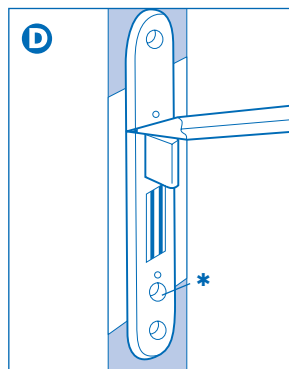

Mark and chisel recess

- D** With lock body inserted, draw around forend on door edge - remember to add removable faceplate before tracing outline. Remove lock and chisel recess to accommodate lock faceplate. Place lock in door and ensure a good fit with faceplate flush with door edge.

NOTE: With lock fitted into door, check that the sashbolt issuitable for your door opening. Gently close door.

The curved edge of the sashbolt (latch) must be facing the door frame, if not, the sashbolt must be reversed - see instructions on reverse of leaflet.

- E** With lock held against door face ensuring faceplate is flush with door edge and in line with lock recess, mark position of the key hole (and spindle). Drill and cut holes on both sides of the door for the key

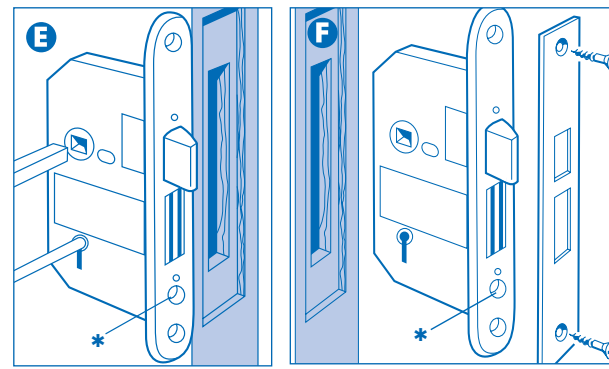

Mark and drill holes

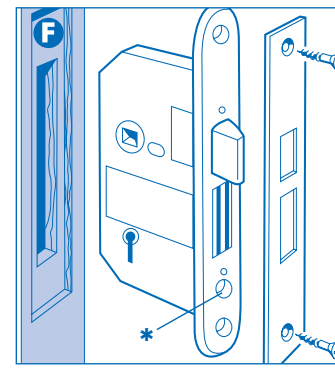

Fit lock

(and spindle). Fit lock flat into door making sure that the key (and spindle) pass freely into the lock.

NOTE: When fitting the Euro sashlock, insert the cylinder retaining screw through the lock end face before fitting the faceplate in position.

- F** With faceplate in position secure lock into door with screws provided. Fit escutcheons and/or door handles with spindle cut to suit. Test for easy working operation.

- G** With the door open and the bolt in the locked position, close door gently against door frame. Mark positions of bottom of bolt and top of latch bolt.

Fitting the Box Striker

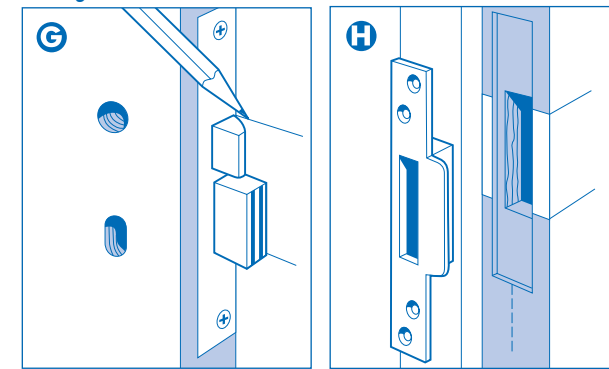

Mark position

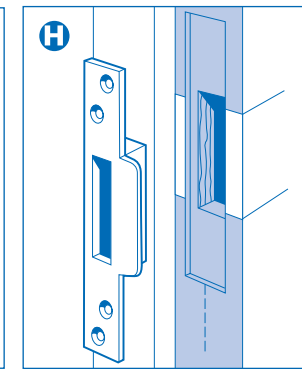

Fit Box Striker

Between these two lines mark a central vertical line (dotted line) on door frame.

- H** Hold box striker up to door frame, ensuring the box section is in line with previous markings. Draw around box section of box striker on door frame. Along the vertical line **G**, drill a series of overlapping holes to the box depth. Hold box striker up to frame and draw around edge of box striker. Remove box striker and chisel out so that box striker sits flush in door frame. Secure the box striker using screws in the central or elongated holes only. Test lock for working operation, and adjust position of box striker if required. When aligned correctly, fit the two remaining screws.