

FITTING INSTRUCTIONS

NEXUS II

FITTING INSTRUCTIONS

- 1** POSITION JIG OVER CENTRED SASH & FRAME & PRE-DRILL

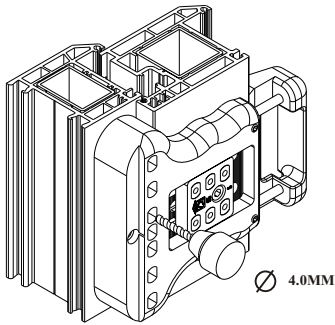

- 2** ADD PACKERS IF REQUIRED & FIX BODY USING 3 X 45mm SCREWS

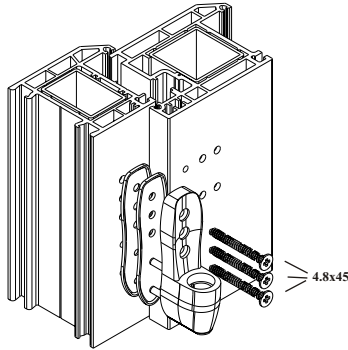

- 3** LOCATE PEG INTO SLOT AND FIRMLY PUSH HINGE PIN INTO BODY

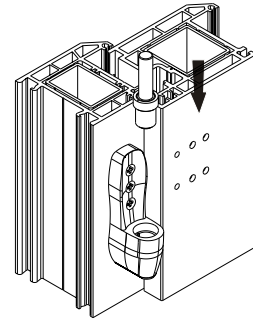

- 4** ENSURE THE ADJUSTER SLEDGE SCREW IS FLUSH WITH THE EDGE OF THE SLEDGE

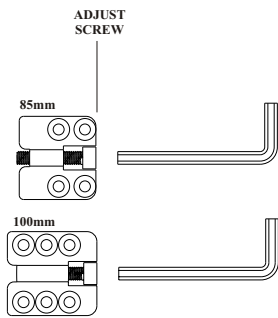

- 5** FIX FLAG TO SASH. USE 25mm SCREWS INTO COVER LEG

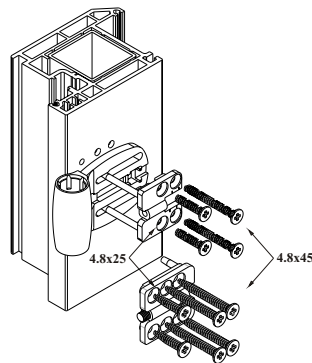

- 6** PRESS COMPRESSION BUSH INTO BODY WITH ALIGNMENT MARK FACING AWAY FROM THE SASH

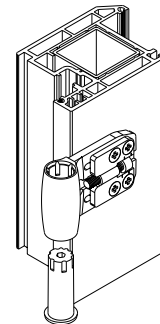

- 7** FIT SASH TO FRAME AND FIX COVER WITH SCREW (INCLUDED)

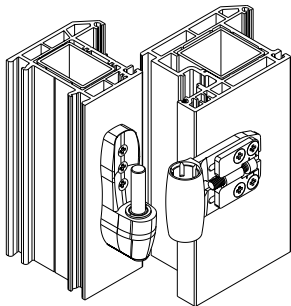

- 8** ADJUST SASH AS NECESSARY

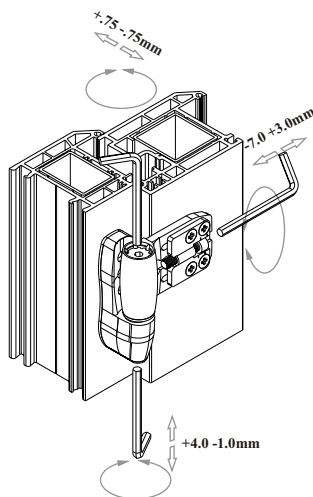

- 9** FIT COVER AND CAPS

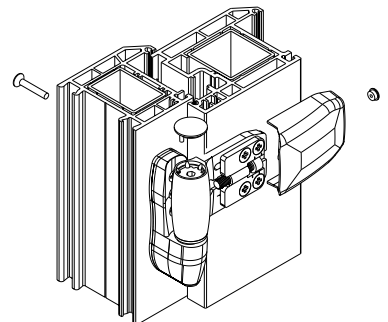

grouphomesafe